

KNIGHT

PROVEN INNOVATORS
of Material Handling Systems

Rails

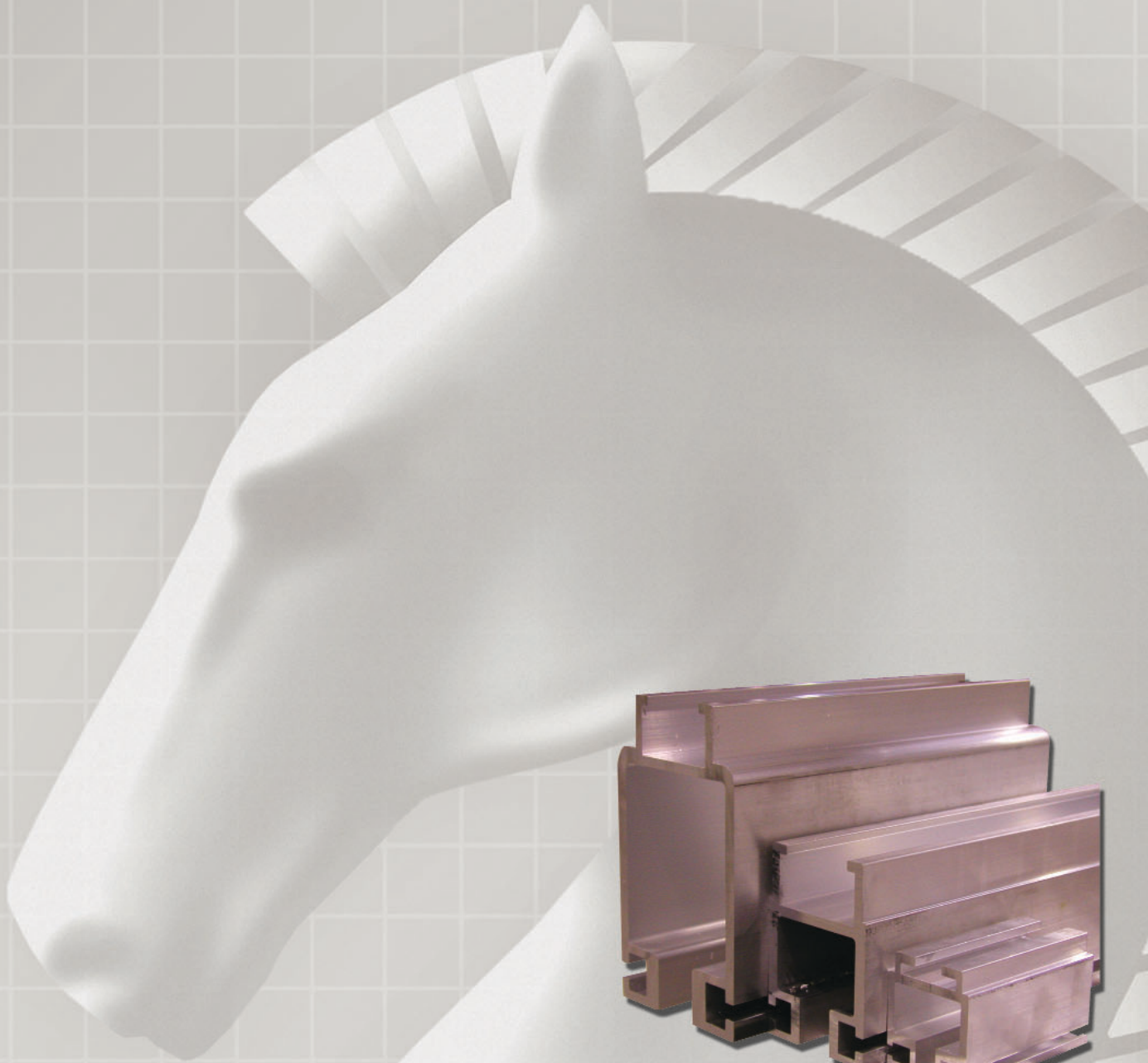

DOBCO
EQUIPMENT LTD

Toll-Free 1-866-763-6226 Phone: 905-672-5557
Fax: 905-672-5559 Email: sales@dobcoeqp.com

Aluminum Rail

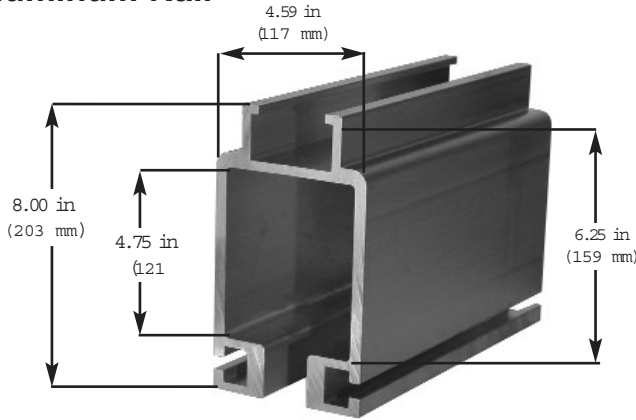

RAD7500

(9.8 lbs/ft - 3.58 kg/m)

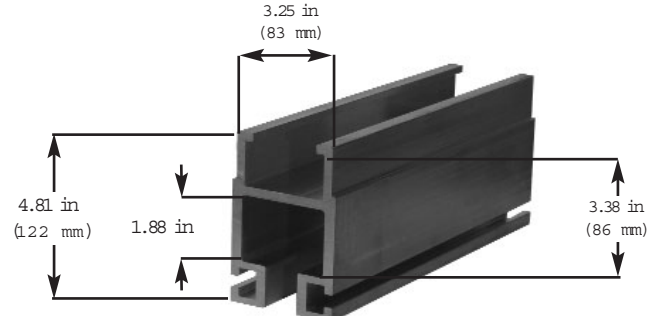

RAD4100 Rail

(5.0 lbs/ft - 2.27 kg/m)

7000 Series Rail and components are compatible with 7500 Series Rail.
 7500 Series will splice to 7000 Series Rail with a MRHA7506 Splice Kit.

4000 Series Rail and components are compatible with 4100 Series Rail.

ft [m]	5 [1.52]	6 [1.83]	7 [2.13]	8 [2.45]	9 [2.74]	10 [3.05]	11 [3.35]	12 [3.66]	13 [3.96]	14 [4.27]	15 [4.57]	16 [4.88]	17 [5.18]	18 [5.49]	19 [5.79]	20 [6.09]	21 [6.40]	22 [6.71]	23 [7.01]	24 [7.31]	25 [7.62]
RAD7500	2500 [1134]	2500 [1134]	2500 [1134]	2500 [1134]	2500 [1134]	2500 [1134]	2000 [907]	2000 [907]	2000 [907]	1850 [839]	1850 [839]	1500 [680]	1500 [680]	1200 [544]	1200 [544]	1100 [499]	1100 [499]	900 [408]	900 [408]	900 [408]	900 [408]
RAD4100	900 [408]	900 [408]	715 [324]	715 [324]	625 [283]	625 [283]	500 [227]	500 [227]	375 [170]	375 [170]	310 [140]	310 [140]	220 [100]	220 [100]	185 [84]	185 [84]	155 [70]	155 [70]	155 [70]	155 [70]	155 [70]

Knight Industries follows material handling industry standards in determining the capacity ratings for enclosed track overhead rail systems. Each component (e.g. rail, hangers, trolleys, etc.) is individually tested to establish its ultimate failure point. From this number, a safe working load (based on a 5:1 safety factor) is then assigned to the component. Each rail span length is then tested to determine the maximum single point load required to achieve a predetermined deflection based on a 1:350 ratio (1" of deflection for each 350" of length). The recommended rated capacity chart is based upon single point loading for the listed spans. The maximum of 2500 lbs. is a function of the 5:1 safety factor for the component with the lowest tested failure point (note that the lowest failure point is in the 15,000 lbs. range; 6804 kg).

Steel Rail

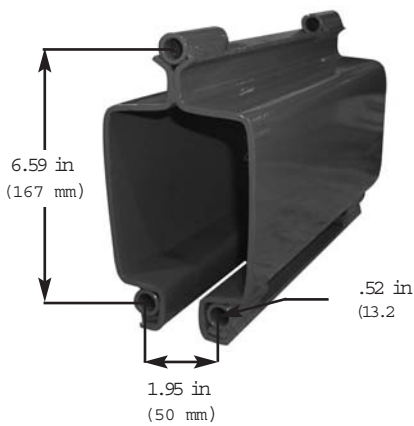

RSD5700

(10.8 lbs/ft - 4.90 kg/m)

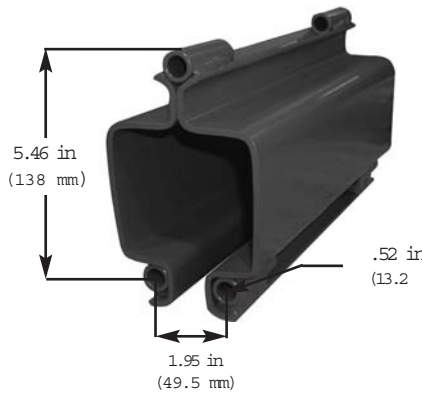

RSD5500

(9.40 lbs/ft - 4.26 kg/m)

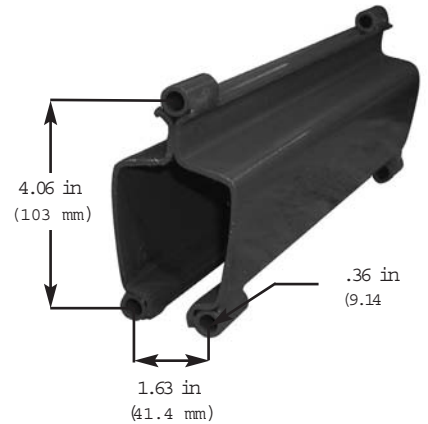

RSD5300

(4.20 lbs/ft - 1.91 kg/m)

ft [m]	5 [1.52]	6 [1.83]	7 [2.13]	8 [2.44]	9 [2.74]	10 [3.05]	11 [3.55]	12 [3.66]	13 [3.96]	14 [4.27]	15 [4.27]	16 [4.88]	17 [5.18]	18 [5.49]	19 [5.79]	20 [6.10]
RSD5700	1000 [454]	1000 [454]	1000 [454]	1000 [454]	1000 [454]	1000 [454]	1000 [454]	1000 [454]	1000 [454]	1000 [454]	1000 [454]	800 [362]	800 [362]	800 [362]	650 [295]	650 [295]
RSD5500	1000 [454]	1000 [454]	1000 [454]	1000 [454]	1000 [454]	1000 [454]	1000 [454]	800 [362]	800 [362]	800 [362]	800 [362]	650 [295]	650 [295]	650 [295]	650 [295]	650 [295]
RSD5300	500 [226]	500 [226]	500 [226]	500 [226]	500 [226]	375 [170]	375 [170]	375 [170]	250 [113]	250 [113]	125 [56]	125 [56]	100 [45]	100 [45]	80 [36]	80 [36]

Knight Steel Rail is for use with direct loads only. Please call Knight Industries for a complete list of steel rail components.

Hangers

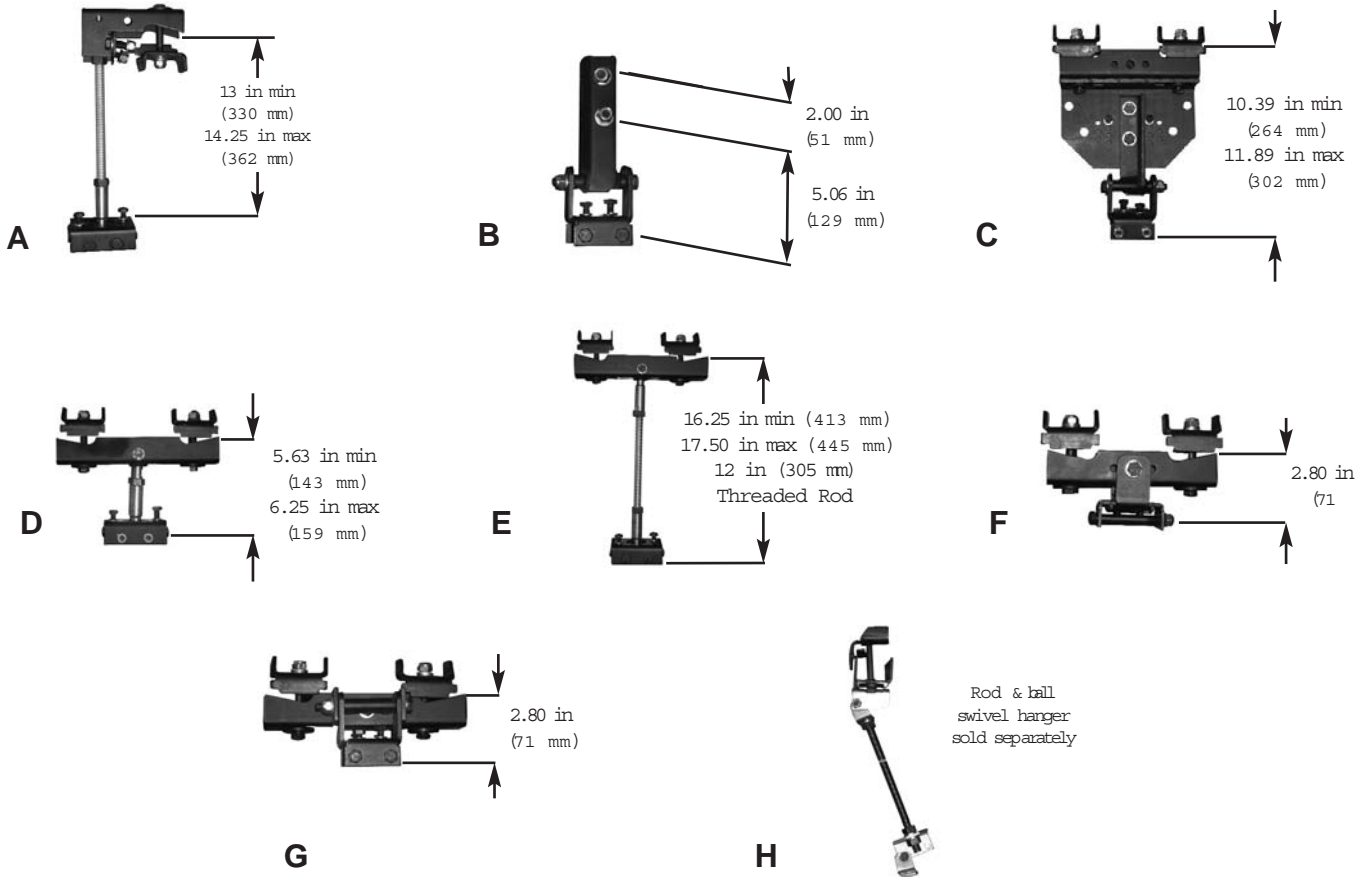

	Model	Description	Structural Steel Flange Size in [mm]	Offset or Direct Load	Adjustable or Fixed Height
A	MRHS4034	Rod & Ball Swivel C-Channel Hanger	2.5 Max [51-127]	Direct	Adjustable
B	MRHA4035	Bolt On C-Channel Hanger	All Sizes	Offset & Direct	Fixed
C	MRHS4038	Parallel or Perpendicular System Hanger	2-5 [51-127]	Offset	Adjustable
	MRHS4039	Parallel or Perpendicular System Hanger	5-7 [127-178]		
	MRHS4218	Parallel or Perpendicular System Hanger	7-9 [178-229]		
	MRHS4342	Parallel or Perpendicular System Hanger	9-11 [229-279]		
D	MRHS4036	Short Stack Rod & Ball Swivel I-Beam Hanger	2-5 [51-127]	Direct	Adjustable
	MRHS4037	Short Stack Rod & Ball Swivel I-Beam Hanger	5-7 [127-178]		
	MRHS4043	Short Stack Rod & Ball Swivel I-Beam Hanger	7-9 [178-229]		
	MRHS4045	Short Stack Rod & Ball Swivel I-Beam Hanger	9-11 [229-279]		
E	MRHS4047	Extended Stack Rod & Ball Swivel I-Beam Hanger	2-5 [51-127]	Direct	Adjustable
	MRHS4049	Extended Stack Rod & Ball Swivel I-Beam Hanger	5-7 [127-178]		
	MRHS4051	Extended Stack Rod & Ball Swivel I-Beam Hanger	7-9 [178-229]		
	MRHS4053	Extended Stack Rod & Ball Swivel I-Beam Hanger	9-11 [229-279]		
F	MRHS4082	Short Stack Parallel I-Beam Hanger	2-5 [51-127]	Offset	Fixed
	MRHS4083	Short Stack Parallel I-Beam Hanger	5-7 [127-178]		
	MRHS4086	Short Stack Parallel I-Beam Hanger	7-9 [178-229]		
	MRHS4087	Short Stack Parallel I-Beam Hanger	9-11 [229-279]		
G	MRHS4076	Short Stack Perpendicular I-Beam Hanger	2-5 [51-127]	Direct	Fixed
	MRHS4095	Short Stack Perpendicular I-Beam Hanger	5-7 [127-178]		
	MRHS4099	Short Stack Perpendicular I-Beam Hanger	7-9 [178-229]		
	MRHS4100	Short Stack Perpendicular I-Beam Hanger	9-11 [229-279]		
H	MRWS4016	Aluminum Rail Sway Bracing	2-5 [51-127]	Offset	Adjustable
	MRWS4142	Aluminum Rail Sway Bracing	5-7 [127-178]		
	MRWS4143	Aluminum Rail Sway Bracing	7-9 [178-229]		
	MRWS4152	Aluminum Rail Sway Bracing	9-11 [229-279]		

7500 Load Trolleys

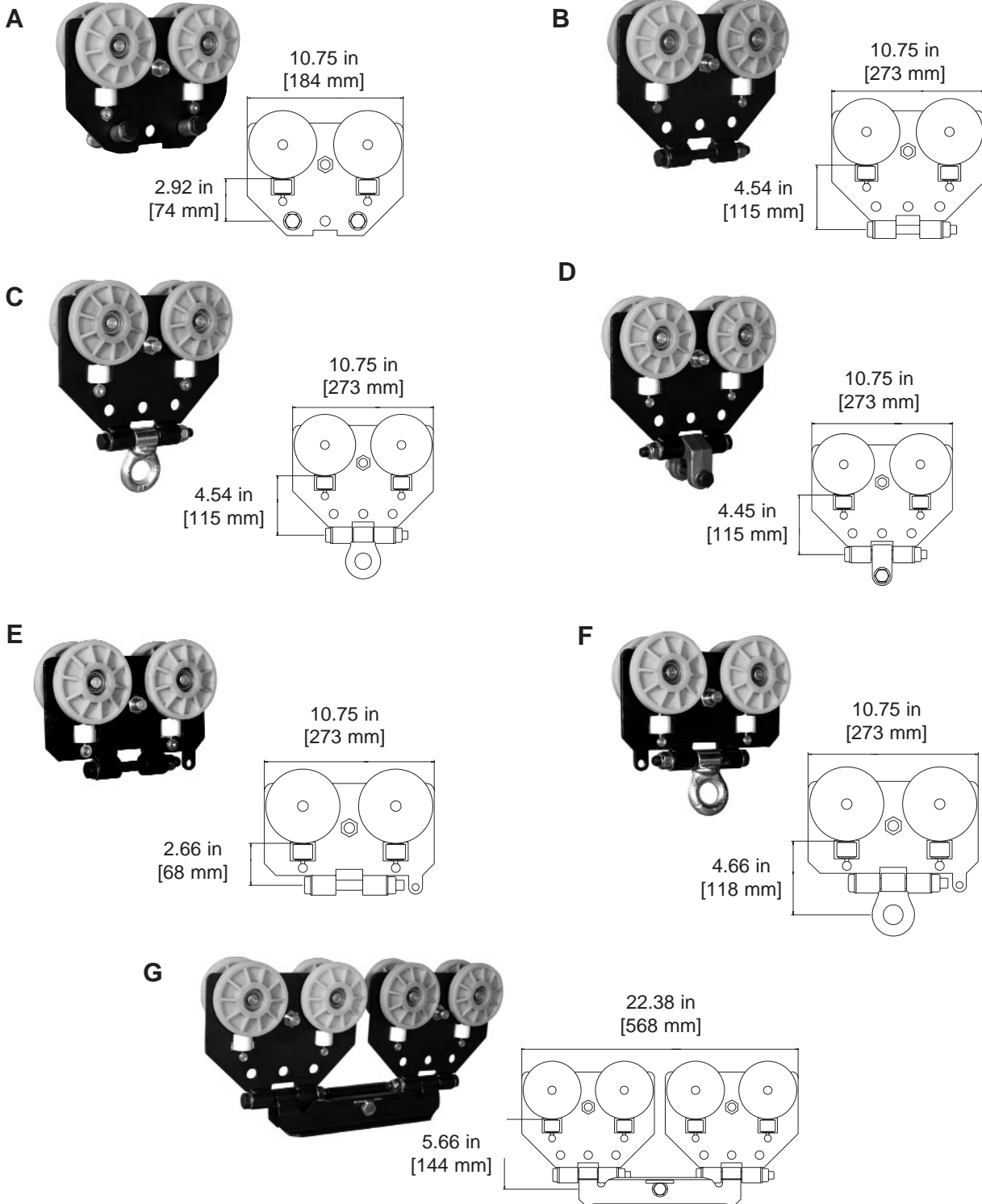

	Model	Description	Part Weight lbs [kg]
A	MRTA7706	Balancer Trolley (Part Weight 11.0 lbs [4.99 kg])	11.0 [4.99]
B	MRTA7002	Boss Trolley	10.5 [4.76]
C	MRTA7719	Boss Trolley with Eye Hook	11.5 [5.22]
D	MRTA7723	Boss Trolley with Yoke	12.5 [5.67]
E	MRTA7765	Low Profile Boss Trolley	8.0 [3.63]
F	MRTA7787	Low Profile Boss Trolley with Eye Hook	8.0 [3.63]

* Trolley dimensions are from the bottom of the rail to the center point of attachment.

7500 Load Trolleys

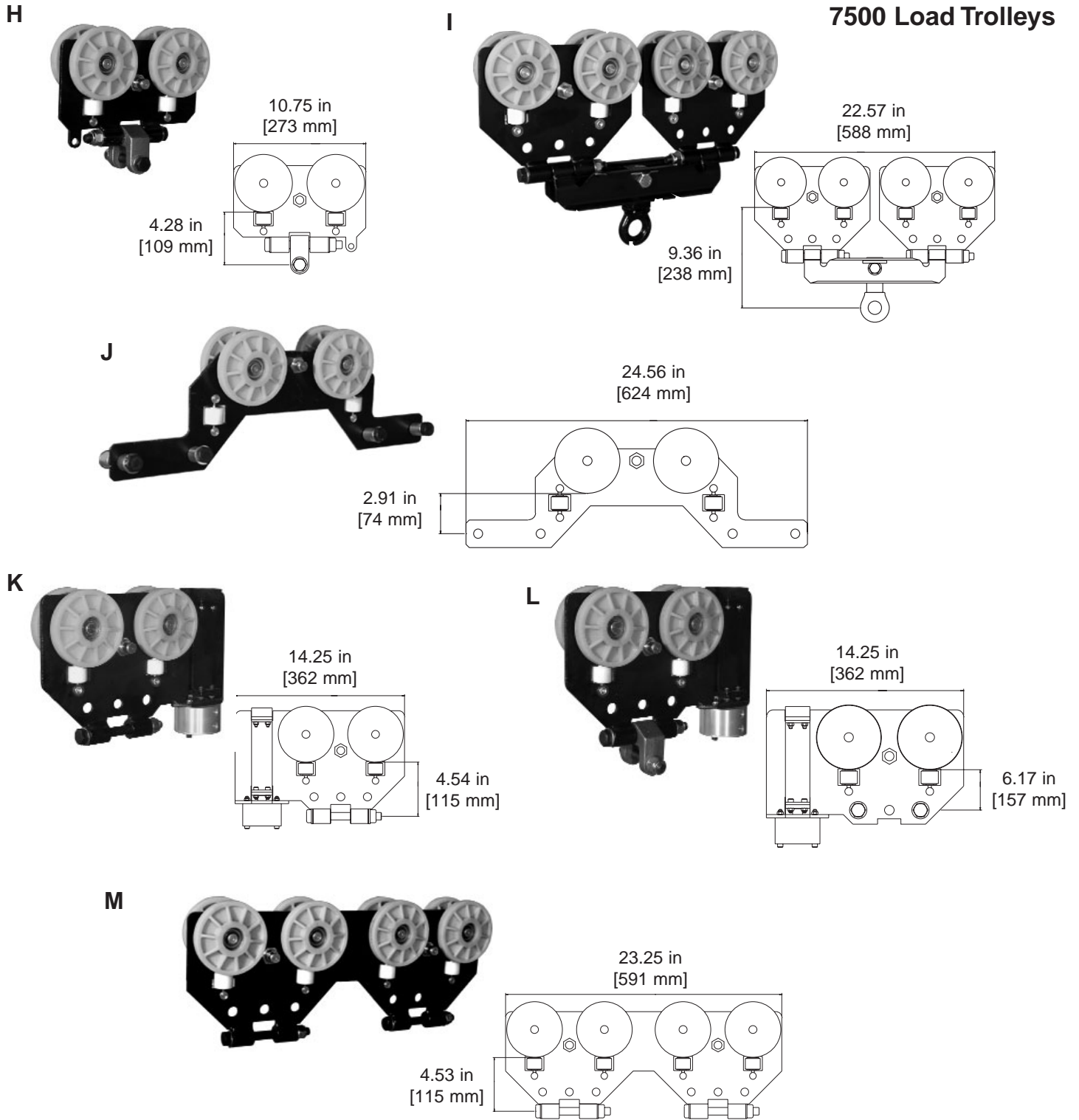

	Model	Description	Part Weight lbs [kg]
G	MRTA7726	Tork Pak Trolley	26.0 [11.79]
H	MRTA7786	Low Profile Boss Trolley with Yoke	10.5 [4.76]
I	MRTA7715	Hoist Trolley	28.5 [12.93]
J	MRTA7793	Air Tractor Trolley Curved Rail	10.2 [4.63]
K	MRTA7794	Rail Brake Load Trolley	7.5 [3.40]
L	MRTA7795	Rail Brake Yoke Trolley	7.7 [3.49]
M	MRTA7784	Same Plane End Truck Trolley	16.5 [7.48]

* Trolley dimensions are from the bottom of the rail to the center point of attachment.

4100 Load Trolleys

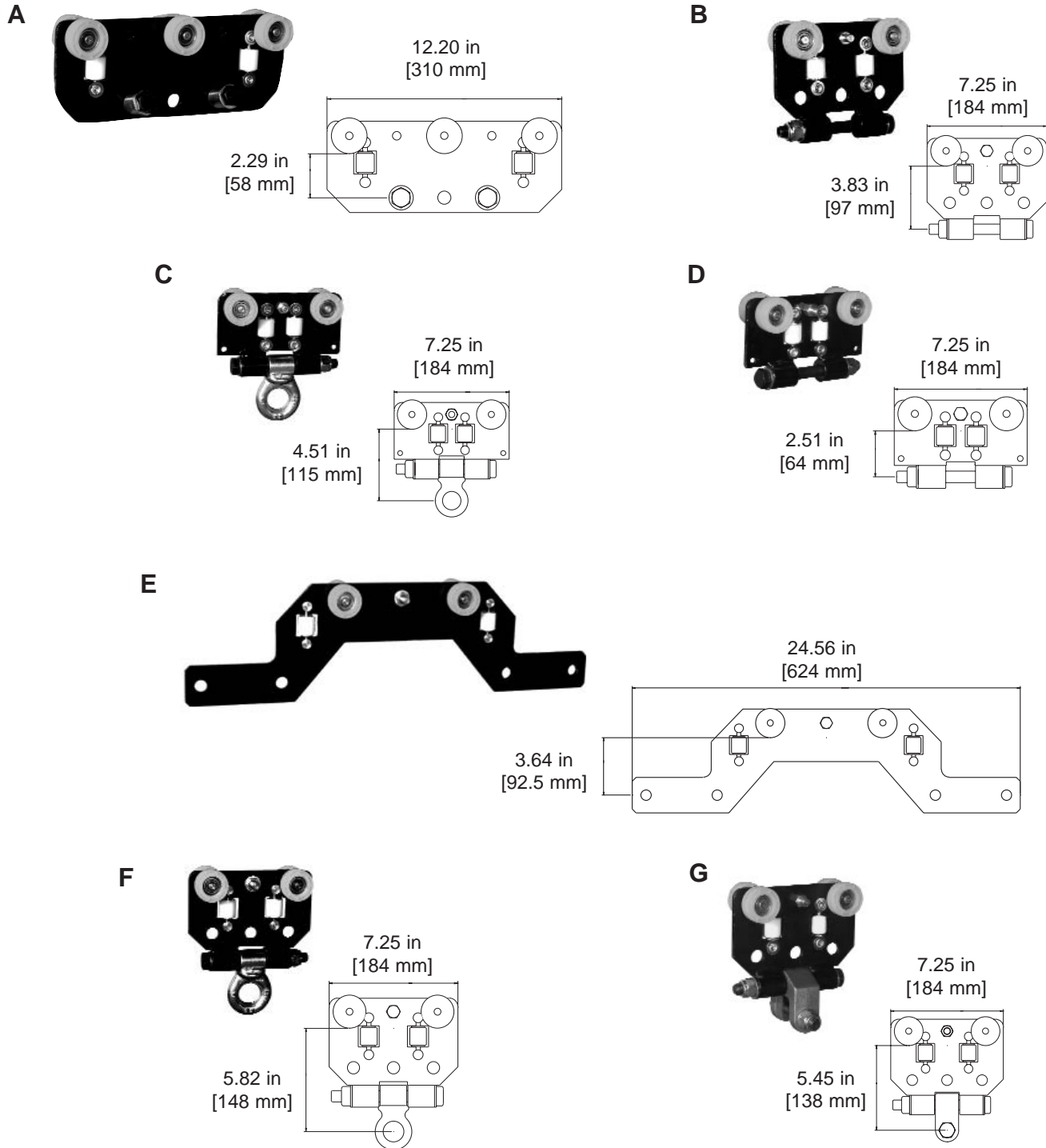

	Model	Description	Part Weight lbs [kg]
A	MRTA4442	Balancer Trolley	6.5 [2.95]
B	MRTA4003	Boss Trolley	4.0 [1.81]
C	MRTA4393	Low Profile Boss Trolley with Eye Hook	4.9 [2.22]
D	MRTA4312	Low Profile Boss Trolley	3.7 [1.68]
E	MRTA4383	Air Tractor Trolley Curved Rail	6.4 [2.90]
F	MRTA4029	Boss Trolley with Eye Hook	5.0 [2.27]
G	MRTA4009	Boss Trolley with Yoke	6.5 [2.95]

* Trolley dimensions are from the bottom of the rail to the center point of attachment.

4100 Load Trolleys

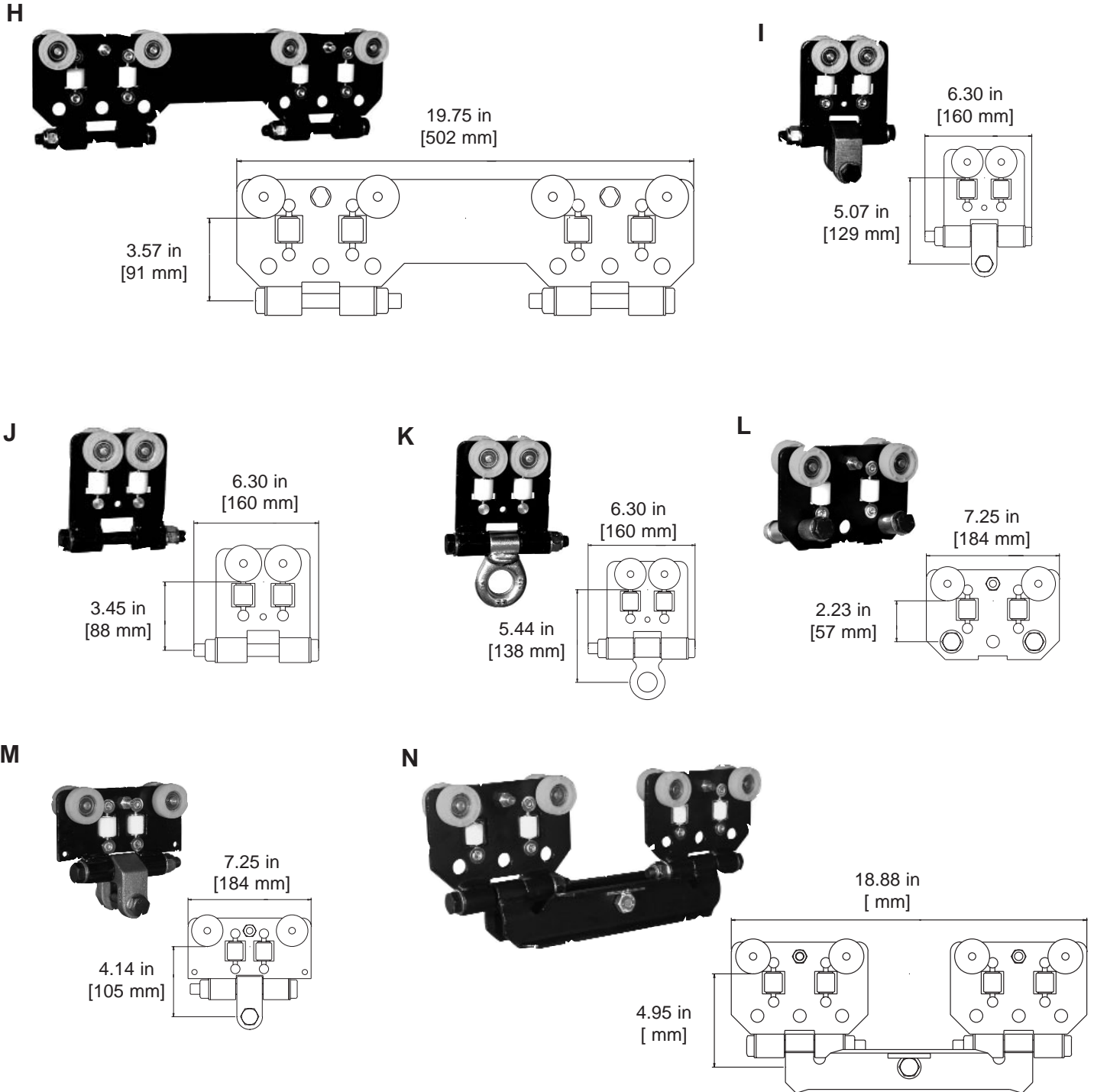

	Model	Description	Part Weight lbs [kg]
H	MRTA4294	Same Plane End Truck Trolley	11.1 [5.03]
I	MRTA4266	Boss Trolley with Yoke Curved Rail	5.8 [2.63]
J	MRTA4112	Boss Trolley Curved Rail	3.3 [1.50]
K	MRTA4391	Boss Trolley with Eye Hook Curved Rail	4.7 [2.13]
L	MRTA4001	Air Tractor Trolley	4.5 [1.81]
M	MRTA4392	Low Profile Yoke Trolley	6.1 [2.77]
N	MRTA4027	Tork Pak Trolley	13.0 [5.90]

* Trolley dimensions are from the bottom of the rail to the center point of attachment.

7500 End Trucks

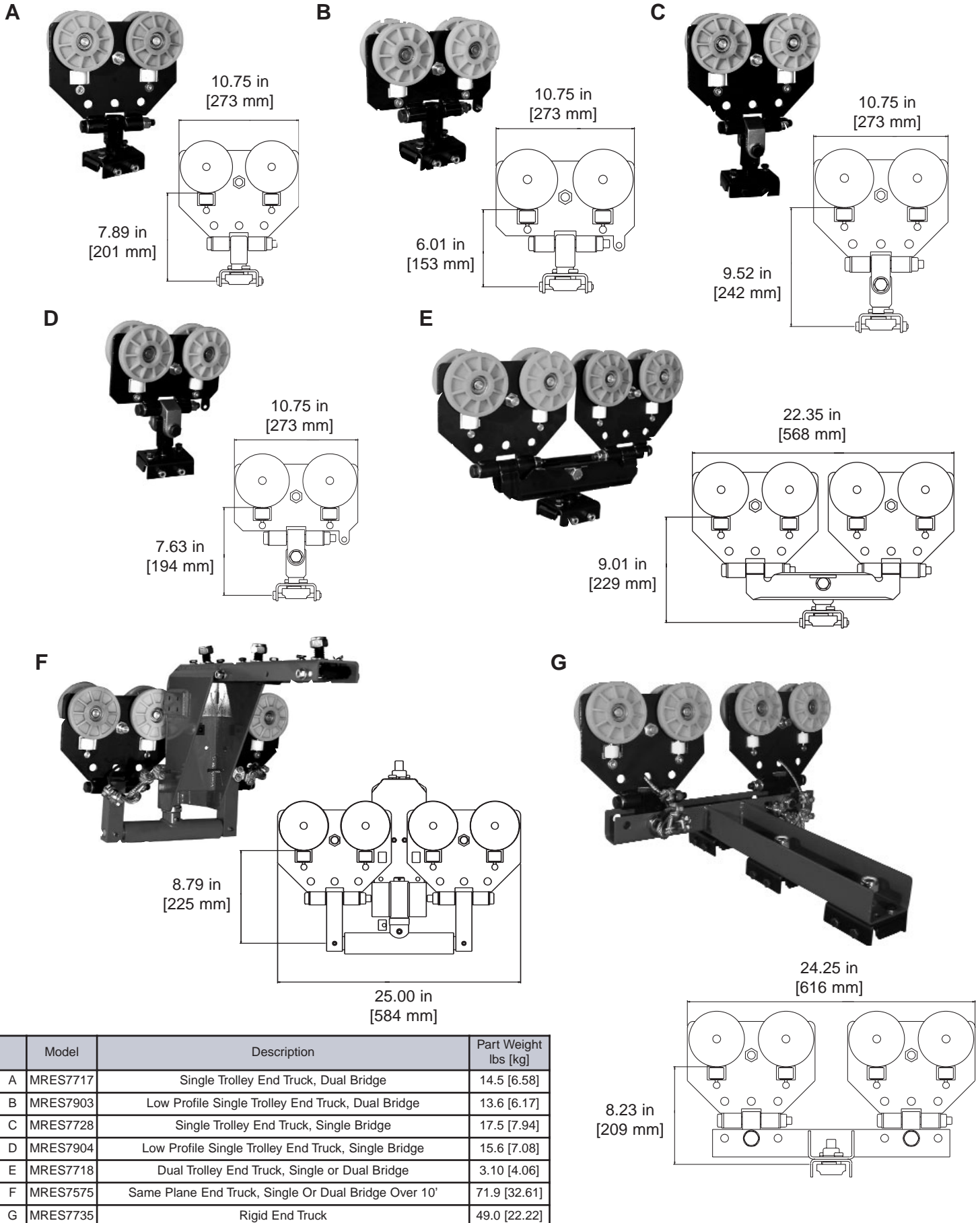

	Model	Description	Part Weight lbs [kg]
A	MRES7717	Single Trolley End Truck, Dual Bridge	14.5 [6.58]
B	MRES7903	Low Profile Single Trolley End Truck, Dual Bridge	13.6 [6.17]
C	MRES7728	Single Trolley End Truck, Single Bridge	17.5 [7.94]
D	MRES7904	Low Profile Single Trolley End Truck, Single Bridge	15.6 [7.08]
E	MRES7718	Dual Trolley End Truck, Single or Dual Bridge	3.10 [4.06]
F	MRES7575	Same Plane End Truck, Single Or Dual Bridge Over 10'	71.9 [32.61]
G	MRES7735	Rigid End Truck	49.0 [22.22]

4100 End Trucks

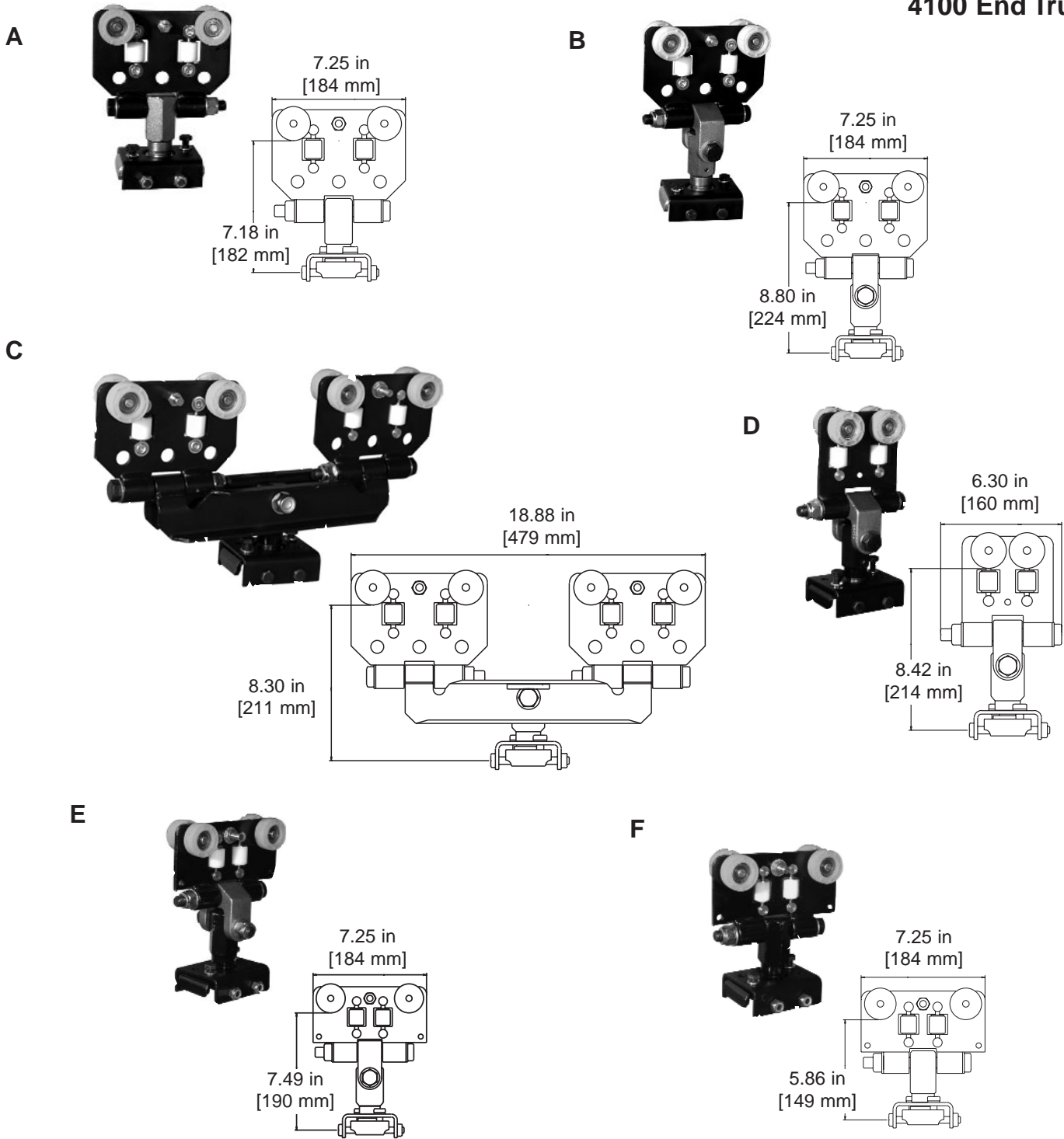

	Model	Description	Part Weight lbs [kg]
A	MRES4072	Single Trolley End Truck, Dual Bridge	19.1 [8.62]
B	MRES4025	Single Trolley End Truck, Single Bridge	11.5 [5.22]
C	MRES4073	Dual Trolley End Truck, Single or Dual Bridge	19.0 [8.62]
D	MRES4403	Single Trolley End Truck, Single Bridge for Curved Rail	9.4 [4.26]
E	MRES4310	Low Profile End Truck, Single Bridge	10.5 [4.76]
F	MRES4311	Low Profile End Truck, Dual Bridge	8.5 [3.86]

* Above end trucks run on 4100 series rail and attach to all Knight aluminum rail.

Rail Accessories



A & B

End Cap serves as a dust cover. Can be used in conjunction with a mid rail stop to form a redundant stop.



C & D

Mid Rail Stop used in conjunction with end caps. Can be used to divide the working area of a bridge or runway.



E & F

Redundant End Cap & Mid Rail Stop Assembly when used together a mid-rail stop and end cap serve as a redundant stop.



G & H

Shock Absorber dampens the impact force of the load trolley striking the end cap.



I - N

Bridge Brace used to secure parallel rails at specific distances. Spans greater than 15 ft require two braces. Custom bridge braces available upon request.



O - Q

Splice Kit joins runways or monorails. A hanger must be used within 1 ft of a splice. A hanger can be used on the splice joint.

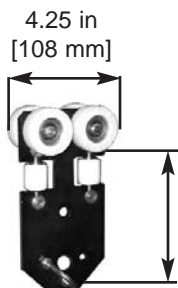

R & S

Hose Trolley carries festooned hose used in hose management kits.

	Model	Description	Part Weight lbs [kg]
A	MRAA4011	End Cap 4100 Series	1.0 [.45]
B	MRAA4804	End Cap 7500 Series	2.5 [1.13]
C	MRAA4455	Mid Rail Stop 4100 Series	1.5 [.68]
D	MRAA7511	Mid Rail Stop 7500 Series	2.0 [.91]
E	MRAS7533	Redundant End Cap and Mid Rail Stop Assembly 7500 Series	5.0 [2.27]
F	MRAS4454	Redundant End Cap and Mid Rail Stop Assembly 4100 Series	2.0 [.91]
G	MRAA4058	End Cap With Shock Absorber 4100 Series	3.0 [1.36]
H	MRAA4805	End Cap With Shock Absorber 7500 Series	5.1 [2.31]
I	MRAA4205-8	Bridge Brace Assembly on 36" centers for 7500 Series	20.5 [9.30]
J	MRAA4205-4	Bridge Brace Assembly on 36" centers for 4100 Series	20.5 [9.30]
K	MRAA4285-8	Bridge Brace Assembly on 30" centers for 7500 Series	19 [8.62]
L	MRAA4285-4	Bridge Brace Assembly on 30" centers for 4100 Series	19 [8.62]
M	MRAA4064-8	Bridge Brace Assembly on 24" centers for 7500 Series	17 [7.71]
N	MRAA4064-4	Bridge Brace Assembly on 24" centers for 4100 Series	17 [7.71]
O	MRHA4445	Splice Kit 4100 Series	4.5 [2.04]
P	MRHA7503	Splice Kit 7500 Series	5.5 [2.49]
Q	MRHA7506	Splice Kit for 7500 to 7000 Series	5.7 [2.59]
R	MRMA4019	Hose Trolley 4100 Series	2.5 [1.13]
S	MRMA4814	Hose Trolley 7500 Series	2.5 [1.13]

Rail Accessories



T - V

Cable Saddle adapts standard hose trolley to accommodate up to 2 in. electrical cable. Custom cable saddles available.



AA & BB

End of Travel Switch provides the availability to mount a EOT switch to a rail system. Trolley mounted actuator has a bypass feature.



DD

Bridge Stop Assembly prevent bridges from colliding into one another.



FF - KK

Inspection Gate allows for the maintenance and inspection of a trolley without disassembling the system. Custom inspection gates available.



LL - MM

Backer an aluminum backer is normally used to reinforce inspection gates. Steel backer for aluminum rail is used to increase system capacity. May affect stack up heights.



W - Z

Hose Management Kit each kit includes a filter/regulator, brackets, fittings and pressure gauge for festooned or coiled hose.



CC

Rail Brake pneumatic stop which allow the operator to park a bridge or arm on the rail.



EE

Telescoping Rail extends the reach beyond the working limits of the bridge.

	Model	Description	Part Weight lbs [kg]
T	MRMA4180	Cable Saddle Up to 3/4" [19 mm] Diameter Cable	.7 [.32]
U	MRMA4181	Cable Saddle Up to 1-1/2" [38 mm] Diameter Cable	.8 [.36]
V	MRMA4436	Cable Saddle Up to 2" [51 mm] Diameter Cable	1.1 [.50]
W	MRMS4065	3/8" Festooned Hose Management Kit	10 [4.54]
X	MRMS4201	1/2" Festooned Hose Management Kit	10.5 [4.76]
Y	MRMS4066	3/8" Coiled Hose Management Kit	32 [14.5]
Z	MRMS4202	1/2" Coiled Hose Management Kit	32.5 [14.74]
AA	MRAA4228	Limit Switch With No Bypass	8.5 [3.86]
BB	MRAA4224	Limit Switch With Bypass	9.0 [4.08]
CC	MRAA4197	Rail Brake	14 [6.35]
DD	MRAA4926	Bridge Stop Assembly	3.5 [1.59]
EE	MRES7522	Telescoping Rail	varies with rail length
FF	MRAA4449	Trolley Inspection Gate 4100 Series	55.4 [20.68]
GG	MRAA4564	Trolley Inspection Gate 4500 Series	57.5 [21.46]
HH	MRSA5122	Trolley Inspection Gate 5300 Series	4.7 [2.13]
II	MRSA5564	Trolley Inspection Gate 5500 Series	12.9 [5.85]
JJ	MRSA5722	Trolley Inspection Gate 5700 Series	14.1 [6.40]
KK	MRAA7758	Trolley inspection Gate 7500 Series	50 [22.68]
LL	RAD4510	Steel Backer for Aluminum Rail	varies with rail length
MM	RAD4434	Aluminum backer	

Linear Rail

Knight Linear Rail

- Low friction carriage is ideal for offset and side loads
- Rail can be mounted to the wall, ceiling or floor
- Carriage supports a variety of Knight articulating arms

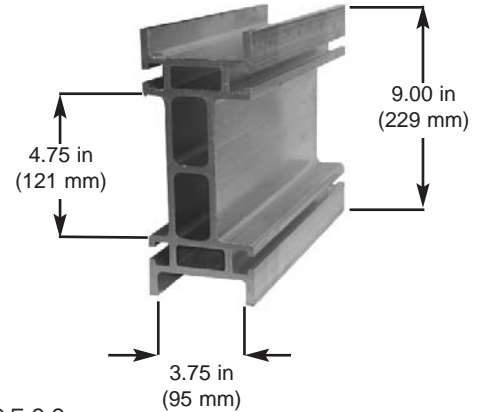
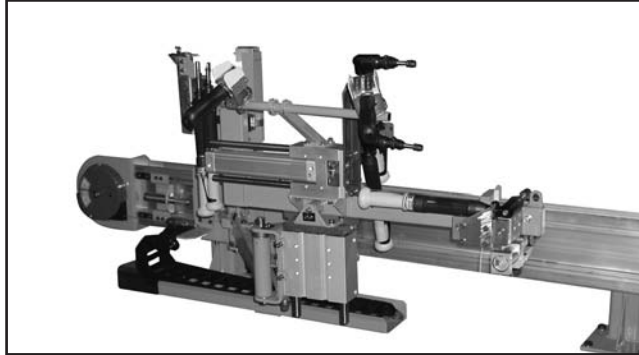

LRAD9500
(10 lbs/ft - 4.54 kg/m)

Round Rail

- Anti kick-up and low profile by design
- Handles high torque values
- Withstands offset loads
- Low resistance
- Ideal for Torque Pak applications
- Air tractors available

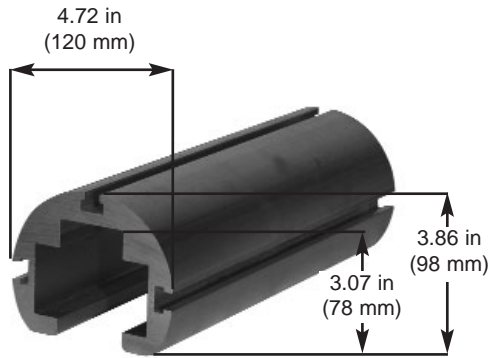

RAD4700
(7 lbs/ft - 3.18 kg/m)

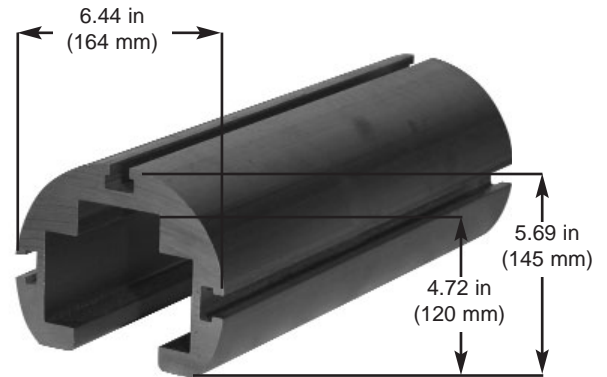

RAD6500
(11 lbs/ft - 4.99 kg/m)

ft [m]	5 [1.52]	6 [1.83]	7 [2.13]	8 [2.44]	9 [2.74]	10 [3.05]	11 [3.35]	12 [3.66]	13 [3.96]	14 [4.27]	15 [4.57]	16 [4.88]	17 [5.18]	18 [5.49]	19 [5.79]	20 [6.09]
RAD6500	1000 [454]	1000 [454]	1000 [454]	1000 [454]	1000 [454]	1000 [454]	750 [340]	750 [340]	**	**	**	**	**	**	**	**
RAD4500	750 [340]	750 [340]	575 [251]	575 [251]	500 [227]	500 [227]	400 [181]	400 [181]	300 [136]	300 [136]	250 [113]	250 [113]	175 [79]	175 [79]	150 [68]	150 [68]

** Lengths in excess of 12 ft [3.66 m] require a hard splice. Ordered in 12 ft [3.66 m] lengths as standard.

Jib Cranes

Knight Jib Cranes have 360° of rotation on thrust bearings for smooth rotation. An efficient inverted L structure allows for maximum hoist height on low head room applications. A two component design makes installation and set up simple. Jib lengths are available up to 14 feet and can be extended by adding an under hung telescoping rail. If your specific capacity is not listed, please contact your Knight representative for more information.



Model	Capacity lbs [kg]	Description
JBA1200	175 [65.3]	Light Duty Jib Crane 3500 Series Tool Rail
MJBA1300	250 [113]	Medium Duty Jib Crane 4100 Series
MJBA2300	350 [159]	Standard Jib Crane 4500 Series
MJBA2600	500 [227]	Heavy Duty Jib Crane 7500 Series

Air Tractor



Air Tractors provide mobility to a load or fixture. Additionally, the load or fixture can be conveyed to the next position or returned home automatically so the operator is free to perform other tasks.

NOTE: TRA2000 Air Tractors already in use can be upgraded for heavier duty applications using the TRA4002 gearbox retrofit kit.

NOTE: Trolleys sold separately - 2 required

Model	Description
TRA4000	(2) Wheel Air Tractor
TRA4001	(2) Wheel Curved Rail Air Tractor
TRA4002	Air Tractor Retrofit Kit

Transfer Switch

Knight Transfer Switch allows fixtures to be transferred from bridge to bridge without the need of cranes, fork trucks or disassembling the system.

Model	Description
MRAS4899	4500 Series Rail Latch
MRAS4897	4500 Series Counter Latch
MRAS5799	5700 Series Rail Latch
MRAS5797	5700 Series Counter Latch

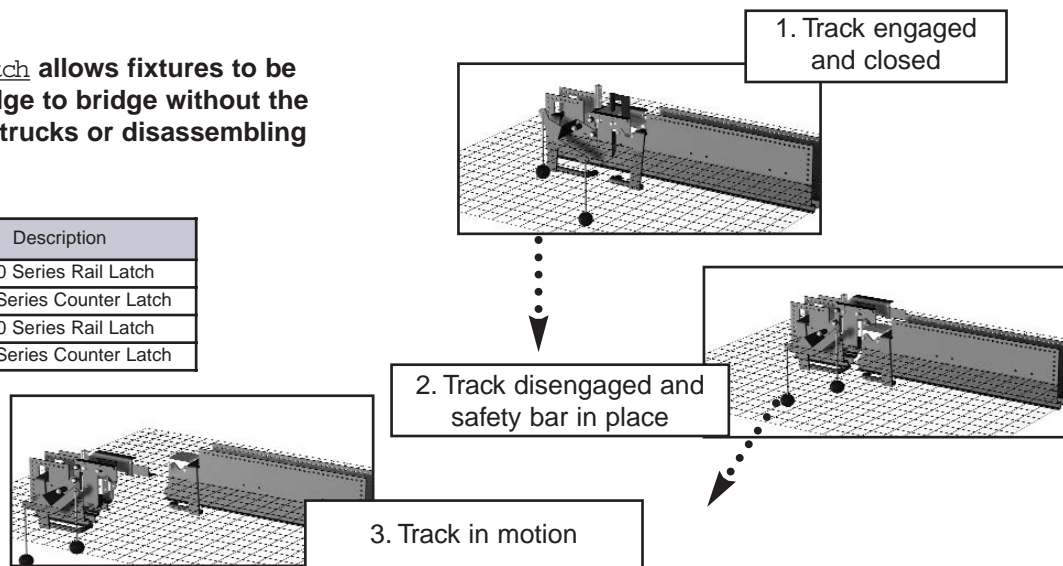

Curved Rail

Part Number	Description	Radius ft [mm]
RAD4100A0390	4100 Series Curved Rail	3.0 [76.2]
RAD4100A0490	4100 Series Curved Rail	4.0 [102]
RAD4100A0590	4100 Series Curved Rail	5.0 [127]
RAD4100A0690	4100 Series Curved Rail	6.0 [152]
RAD7500A0590	7500 Series Curved Rail	5.0 [127]
RAD7500A0690	7500 Series Curved Rail	6.0 [152]
RAD7500A0790	7500 Series Curved Rail	7.0 [178]
RAD7500A0890	7500 Series Curved Rail	8.0 [202]

KNIGHT CURVED RAIL available for 4 in (105 mm) and 8 in (203 mm) aluminum rail. Minimum radius is 3 ft (76.2 mm) for the 4 in (102 mm) rail and 6 ft (152 mm) minimum radius for 8 in (203 mm) rail.

Tool Rail

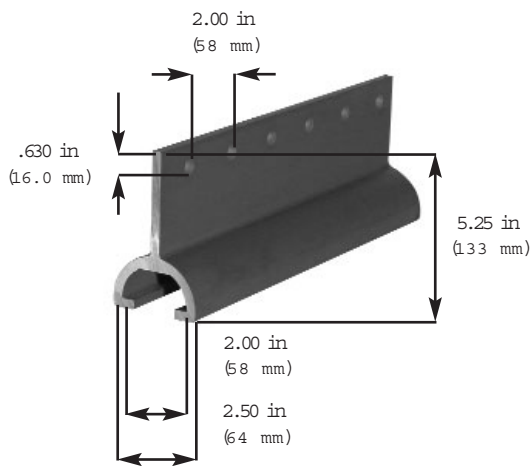

HAD3500 RAIL

2.6 lbs/ft - 1.18 kg/m

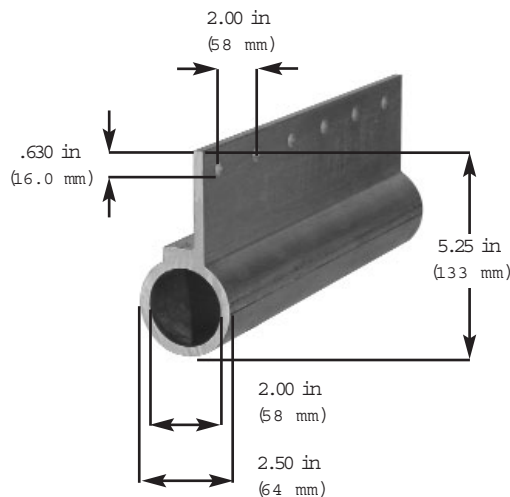

HAD3000 RAIL

3.3 lbs/ft - 1.50 kg/m

ft [m]	5 [1.52]	6 [1.83]	7 [2.13]	8 [2.44]	9 [2.74]	10 [3.05]	11 [3.55]	12 [3.66]	13 [3.96]	14 [4.27]	15 [4.27]	16 [4.88]	17 [5.18]	18 [5.49]	19 [5.79]	20 [6.10]
HAD3000	125 [57]	125 [57]	125 [57]	125 [57]	125 [57]	125 [57]	125 [57]	125 [57]	125 [57]	125 [57]	125 [57]	125 [57]	113 [51]	100 [45]	91 [41]	82 [37]
HAD3500	125 [57]	125 [57]	125 [57]	125 [57]	125 [57]	125 [57]	122 [56]	104 [47]	84 [38]	77 [35]	70 [31]	60 [27]	54 [24]	52 [23]	46 [20]	11 [19]

Tool Rail Trolleys & Accessories

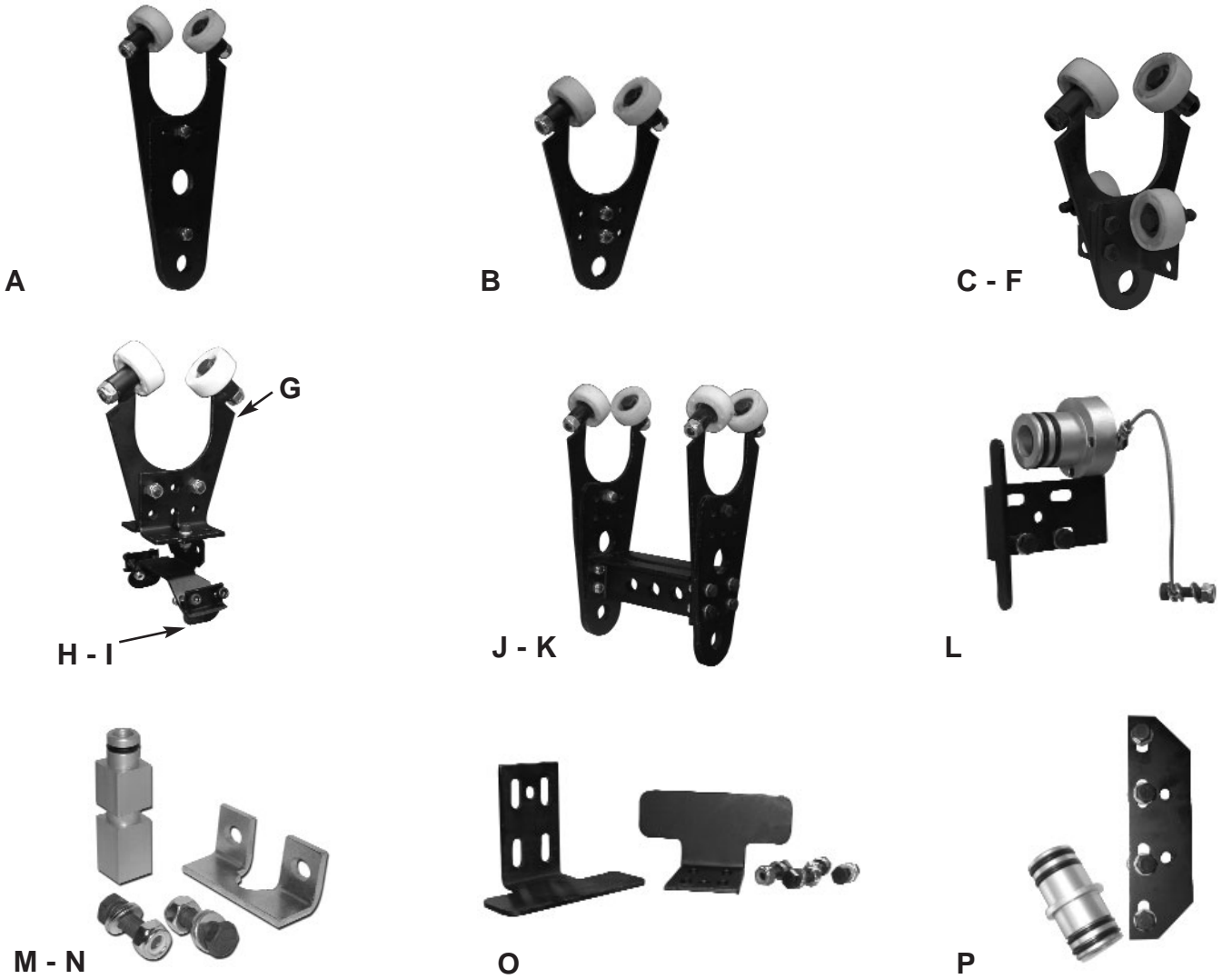

	Model	Description
A	MHTA3009	Trolley 3000 And 3500 Series
B	MHTA3011	Low Profile Trolley 3000 And 3500 Series
C	MHTA3027	Trolley With Anti Kick Up Wheel 3000 Series
D	MHTA3010	Low Profile Trolley 3000 Anti Kick Up Wheel 3000 Series
E	MHTA3028	Dual Trolley with Anti Kick Up Wheel 3000 Series
F	MHTA3029	Low Profile Dual Trolley With Anti Kick Up Wheel 3000 Series
G	MHTA3013	Trolley Mount 3000 And 3500 Series
H	MHMA3180	3/4" [19 mm] Cable Saddle HTA3013 Trolley with Mount
I	MHMA 3181	1 1/2" [38 mm] Cable Saddle HTA3013 Trolley with Mount
J	MHTA3018	Dual Trolley 3000 And 3500 Series
K	MHTA3016	Low Profile Dual Trolley 3000 And 3500 Series
L	MHAA3019	End Cap Assembly With 1" NPT Air Inlet 3000 Series
M	MHAA3015	3/8" NPT Air Outlet 3000 Series
N	MHAA3025	1/2" NPT Air Outlet 3000 Series
O	MHAA3020	End Cap 3500 Series or Mid Rail Stop 3000 And 3500 Series
P	MHAA3012	Splice Kit 3000 Series
Q	MHAA3021	Splice Kit 3500 Series

